

# JUPITER-9000K-H0 / STS-6000K/3000K-H1 Smart Transformer Station



**Simple**

Prefabricated and Pre-tested, No Internal Cabling Needed Onsite  
Compact 20' HC Container Design for Easy Transportation



**Efficient**

High Efficiency Transformer for Higher Yields  
Lower Self-consumption for Higher Yields



**Smart**

Real-time Detection of Transformer, LV Panel and RMU  
High Precision Sensor of LV Electricity Parameters  
Remote Control of ACB and MV Circuit Breaker



**Reliable**

Robust Design against Harsh Environments  
Optimal Cooling Design for High Availability and Easy O&M  
Comprehensive Tests from Components, Device to Solution

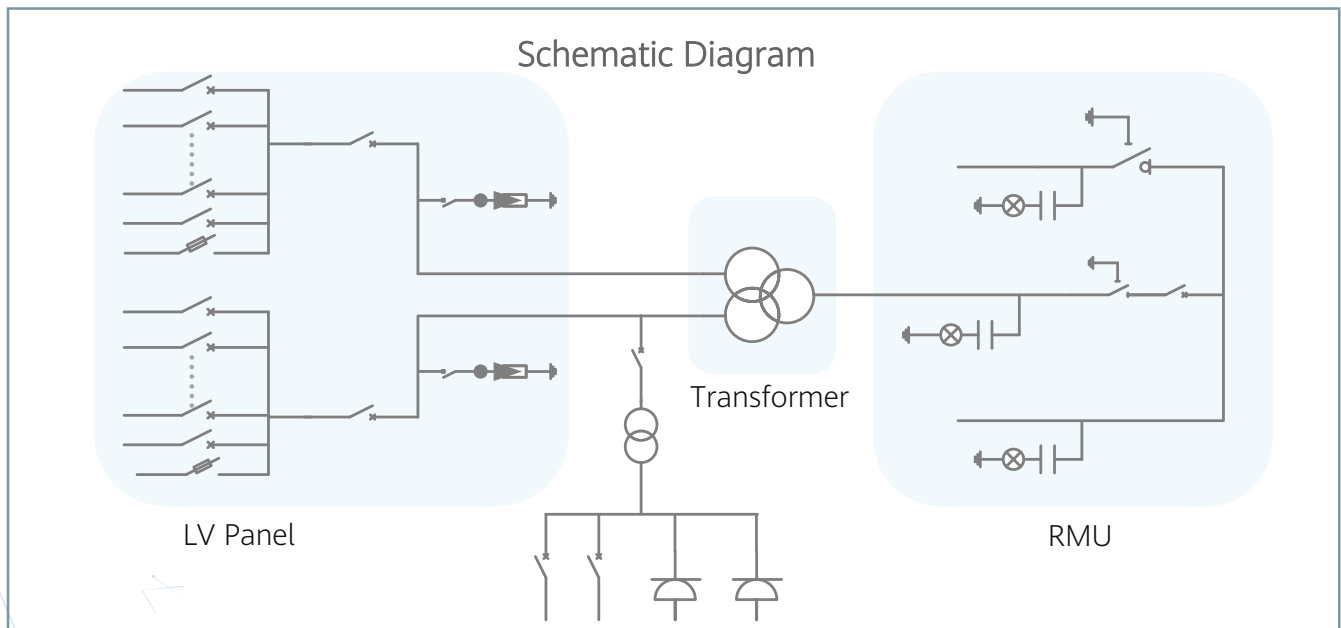

# Technical Specifications

Technical Specifications	JUPITER-9000K-H0	STS-6000K-H1	STS-3000K-H1
<b>Input</b>			
Available Inverters	SUN2000-215KTL-H0		
Max. LV AC Inputs	44	34	17
AC Power	9,000 kVA @40°C <sup>1</sup>	6,800 kVA @40°C <sup>1</sup>	3,400 kVA @40°C <sup>1</sup>
Rated Input Voltage	800 V		
LV Panel Segregation	Form 2b		
LV Main Switches	ACB (4,000 A, 2 x 1 pcs)	ACB (2,900 A, 2 x 1 pcs)	ACB (2,900 A, 1 pcs)
LV Main Switches for SUN2000-215KTL-H0	MCCB (250 A, 2 x 22 pcs)	MCCB (250 A, 2 x 17 pcs)	MCCB (250 A, 17 pcs)
<b>Output</b>			
Rated Output Voltage	10~35 kV <sup>2</sup>		
Frequency	50 Hz / 60 Hz		
Transformer Type	Oil-immersed, Conservator Type		
Transformer Cooling Type	ONAN		
Transformer Tappings	± 2 x 2.5%		
Transformer Oil Type	Mineral Oil (PCB Free)		
Transformer Vector Group	Dy11-y11		Dy11
Transformer Min. Peak Efficiency Index	Tier 1 or Tier 2 In Accordance with EN 50588-1		
RMU Type	SF <sub>6</sub> Gas Insulated		
RMU Transformer Protection Unit	MV Vacuum Circuit Breaker Unit		
RMU Cable Incoming / Outgoing Unit	Direct Cable Unit or Cable Load Break Switch Unit		
Auxiliary Transformer	Dry Type Transformer, 5 kVA, Single-phase, li0	Dry Type Transformer, 5 kVA, Three-phase, Dyn11	
Output Voltage of Auxiliary Transformer	230 / 127 Vac	400 / 230 Vac or 220 / 127 Vac	
<b>Protection</b>			
Transformer Detection & Protection	Oil Level, Oil Temperature, Oil Pressure and Buchholz		
Protection Degree of MV & LV Room	IP 54		
Internal Arcing Fault of STS	IAC A 20 kA 1s		
MV Relay Protection	50/51, 50N/51N		
LV Overvoltage Protection	Type I+II		
Anti-rodent Protection	C5-Medium		
<b>Features</b>			
2 kVA UPS	Optional <sup>3</sup>		
MV Surge Arrester for MV VCB	Optional <sup>3</sup>		
<b>General</b>			
Dimensions (W x H x D)	6,058 x 2,896 x 2,438 mm (20' HC ISO Container)		
Weight	< 28 t	< 22 t	< 15 t
Operating Temperature Range	-25°C ~ 60°C <sup>4</sup>		
Relative Humidity	0% ~ 95% (Non-condensing)		
Max. Operating Altitude	1,000 m <sup>5</sup>		
MV-LV AC Connections	Prewired and Pretested, No Internal Cabling Onsite		
LV & MV Room Cooling	Smart Cooling without Air-across for Higher Availability		
Communication	Modbus TCP, Preconfigured with SmartACU2000D	Modbus RTU, Preconfigured with SmartACU2000D	
<b>Standards Compliance</b>			
IEC 62271-202, EN 50588-1, IEC 60076, IEC 62271-200, IEC 61439-1			

1: More detailed AC power of STS, please refer to the de-rating curve.  
 2: Rated output voltage from 10 kV to 35 kV, more available upon request  
 3: Extra expense needed for optional features which standard product doesn't contain, more options upon request.  
 4: When ambient temperature ≥55°C, awning shall be equipped for STS on site by customer.  
 5: For higher operating altitude, pls consult with Huawei.